

- System Components:**
- (1) 602RF – 1 Amp Regulated Power Supply w/ Fire Alarm Interface
 - (1) 920 – Digital Indoor/Outdoor Keypad
 - (1) 1576U – 1200lb Gate Indoor/Outdoor EMLock®
 - (1) 1576-ZB – Optional Inswing Door Z-Bracket for 1576U
 - (1) MD-31D – PIR Request-to-Exit Sensor
 - (1) 423MU – Green “Push to Exit” Button w/ Fixed 30-second timer
 - (2) RB12V7 – 8Ah 12VDC Backup Battery

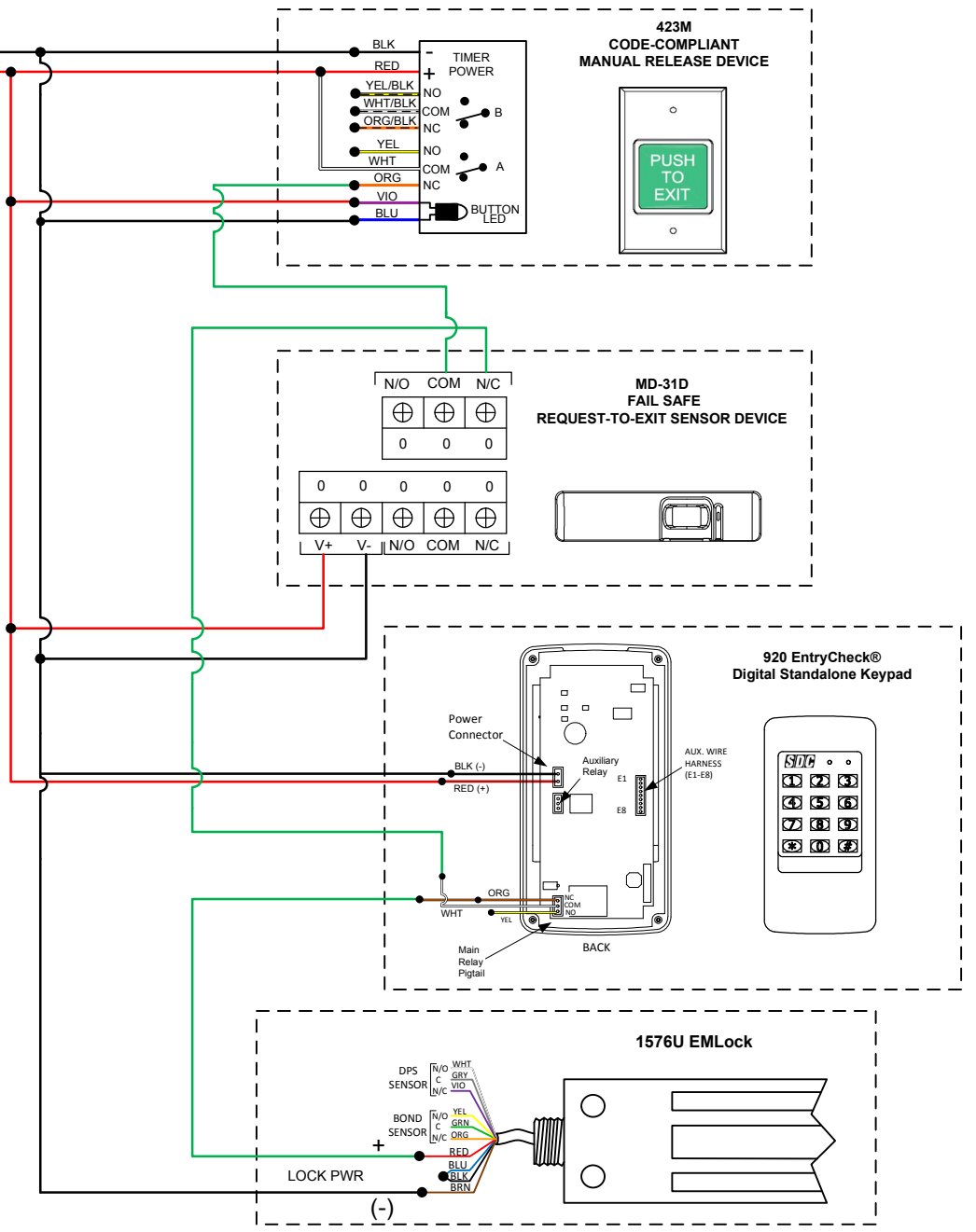

Method of Operation:
Door is normally closed and locked.

Authorized Access:
Entering a valid user code on the keypad will momentarily unlock the magnetic lock allowing the door to be opened. The unlock time will be configured by keypad programming.

The keypad may also be programmed for maintained (On-Off) access.

Authorized Egress:
Activating the Request-to-Exit (REX) motion sensor will unlock the magnetic lock allowing the door to be opened. The unlock time will be configured by the motion sensor dip switch settings.

Manual Release Override:
Pressing the code compliant “Push to Exit” push button will bypass the keypad and motion sensor, unlocking the magnetic lock for a fixed 30 seconds.

Fire & Life Safety:
A signal from the Fire Alarm Panel will immediately unlock the magnetic lock.

- NOTES:**
- (1) ALL LOW VOLTAGE SIGNAL WIRING SHALL BE 18-GAUGE MINIMUM. THE MINIMUM INDUCTIVE LOAD (LOCK) POWER WIRE GAUGE SHALL BE DETERMINED PER THE SDC WIRE GAUGE CHART. ALL WIRING (SINGLE OR MULTI-CONDUCTOR) SHALL BE COLOR CODED WITHOUT SPLICES. A MINIMUM OF TWO SPARE CONDUCTORS IS RECOMMENDED.
 - (2) SPECIFY VOLTAGE WHEN ORDERING PRODUCTS. VOLTAGE IS NOT SPECIFIED ON THIS WIRE DIAGRAM, BE SURE ALL PRODUCTS ARE VOLTAGE COMPATIBLE.
 - (3) ALL WIRING MUST CONFORM TO NATIONAL, STATE AND LOCAL CODES.
 - (4) ALWAYS CONSULT WITH THE AUTHORITY HAVING JURISDICTION (AHJ) BEFORE INSTALLATION.
 - (5) WHERE REQUIRED BY CODE, CONNECT FAILSAFE SYSTEMS TO THE LOCAL FIRE LIFE SAFETY SYSTEM FOR EMERGENCY RELEASE.
 - (6) DOOR POSITION SWITCHES SHOWN WITH THE DOOR CLOSED

<p>Security Door Controls 801 Avenida Acaso Camarillo, CA 93012 f 805.494.0622 ~ f 805.494.8861 www.sdcsecurity.com</p>	<p>NOTE: ALL WIRING MUST BE REVIEWED AND APPROVED BY THE PROJECT ENGINEER ASSIGNED TO THE LOCATION FOR ITS CORRECTNESS AND SUITABILITY FOR THE APPLICATION IN WHICH THE EQUIPMENT IS INSTALLED AND OPERATED. ALL WIRING MUST CONFORM TO NATIONAL, STATE, AND LOCAL CODES FOR CLASS 2 FIRE PROTECTION AND CONTROL DEVICES.</p>	PROJECT NAME: Solution #6 - Single Access Controlled Code Compliant Door	TITLE: Code Compliant Access Controlled Egress Door	SO NO.: --	REV: -	
		LOCATION.: --	DIST.: --	CONTACT: --	DATE: --	DRAWN BY: --