

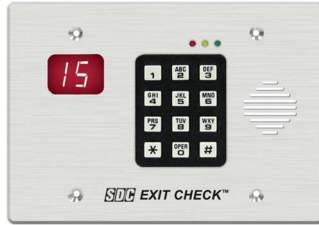

INSTALLATION INSTRUCTIONS

S6000DE / S6000KDE DELAYED EGRESS DEVICE

MODELS



S6000DE



S6000KDE

**PUSH UNTIL ALARM
SOUNDS. DOOR CAN BE
OPENED IN 15 SECONDS.**

**Verbal Exit Instructions or
Alarm Tone Only and
Digital Countdown Display**



Rim Mount, Surface Vertical Rod, or Mortise Exit Device

NOTE: SDC 600 Series Power Supply required

Application:

When unauthorized egress is initiated SDC Exit Check® delays egress through the door for 15 seconds (or 30 seconds). Meanwhile, the person exiting must wait while personnel or security responds. The exit device unlocks after 15 seconds have elapsed, permitting egress. When powered by a fire control supervised power supply, the exit device will allow egress immediately in an emergency.

The integral verbal message, digital countdown display and sign provide comprehensive and clear instructions of the door operation for persons without prior knowledge of the exit delay, including the sight and hearing impaired.

The digital keypad eliminates the need to carry and locate keys for reset and bypass functions.

Features:

Egress Delay

- 15 or 30 second exit delay
- 1 or 2 second nuisance delay

Built-In 3 Function keypad

- Alarm and lock reset
- 1 to 30 second bypass
- Sustained bypass
- Additional key switch optional

Control Inputs

- 1 to 30 second request-to-exit and bypass input with anti-tailgate and jumper selectable door prop alarm.
- Reset

Trigger Modes

- Egress alarm triggered by Push Bar
- Trigger input from external device field selectable (N/O or N/C)

Built-In Annunciation

- Armed mode
- Nuisance mode
- Irreversible egress mode
- Release mode
- Digital countdown mode
- Field selectable voice notification or tone
- Field selectable male voice with security message or female voice with safety message

Monitoring Outputs

- Egress initiation status
- Secure/unsecure status

Choice of Mounting

- Recessed mounted (3 gang metal plaster ring included)
- Surface mounted with optional 3 gang box (DEC-J)
- Optional shroud (SHD-J) to be used with DEC-J surface box.

Exit Check® Applications include:

- Restricting the egress of wandering patients for their own safety.
- HUGS® Infant Protection System compatibility
- Restricting the egress of commercial center patrons for security application needs.
- Controlling pedestrian traffic in transportation facilities, including airport jetways and tarmacs
- Reducing Shoplifting and Employee Theft

Code Compliance

- IFC International Fire Code
- IBC International Building Code
- NFPA 101 Life Safety Code
- NFPA 1 Uniform Fire Code
- California Building Code
- Field selectable automatic or manual power up after emergency release or power loss. Use of manual power up complies with California Building Code (OSHPD) requirements.

Any suggestions or comments to this instruction or product are welcome. Please contact us through our website or email engineer@sdsecurity.com



101-DE/101-KDE Operational Description

The door is closed and secured by latching hardware. The model 101-DE/101-KDE Exit Check controller sends power to the Delayed Egress Panic Device to lock the door in the secured position. The integral digital display shows the unlock delay time.

Activation / Alarmed Release :

Activation of the Exit Check's trigger input initiates the 15 or 30 second unlock cycle . A pre-activation warning tone is sounded during the short nuisance delay period and the integral display starts counting down. To prevent false alarms, removing the trigger input activation during the nuisance delay period will silence the pre-activation warning tone, reset the countdown display and keep the door locked.

Once the nuisance delay period has been exceeded, the Exit Check continues to count down during an irreversible door release cycle. The integral digital countdown display and voice commands continue to inform the person intending to exit of the seconds remaining until unlock. An alarm output is activated to alert personnel of an unauthorized exit. After the 15 or 30 second delay cycle has expired, the Exit Check will remove power to the locking device, allowing free egress.

Reset / Relock:

The Exit Check can be manually reset by authorized personnel by closing the door and entering a code on the integral digital keypad, momentarily turning the optional reset key switch to the reset position, or by momentarily activating a N/O switch connected to the remote reset terminals.

Request to Exit / Authorized Bypass:

A Request-to-Exit (REX) cycle is initiated by entering an authorized REX code on the integral digital keypad, momentarily turning the optional key switch to the bypass position, or momentarily activating a N/O switch connected to the REX terminals. The power will be removed from the locking device allowing free egress. After the request to exit cycle has expired, the Exit Check will automatically reapply power to the locking device to re-secure the door.

Unlocking the door for extended periods of time (Authorized Bypass mode) is accomplished by entering an Authorized Bypass code on the integral keypad, turning the optional key switch to the Bypass position or placing a maintained closure across REX terminals. Releasing the closure across the REX terminals will initiate the Request to Exit cycle. Entering the Reset code on the integral digital keypad, or momentarily turning optional key switch to the Reset position will immediately reapply power to the locking device to re-secure the door.

(NFPA-101)

The 101-DE/101KDE operation complies with the following building and fire codes: NFPA 101; NFPA 1-UFC; UBC; IBC; IFC; SBC; California Building Code. Listings: UL Listed: Special Locking Arrangements and Auxiliary Locks; California State Fire Marshal (CSFM) Listed.

Option Code	Delay Release Time	Nuisance Time	Reset after Alarm	Lock Status on Power-Up
NA	15 sec or 30 sec Selectable	1 sec or 2 sec Selectable	Manual	Locked or Unlocked Selectable
ND	15 sec Fixed	0 sec or 1 sec Selectable	Manual	Locked or Unlocked Selectable
NH	30 sec Fixed	0 sec or 1 sec Selectable	Manual	Locked or Unlocked Selectable
NC (CBC Compliant)	15 sec Fixed	0 sec or 1 sec Selectable	Manual	Unlocked Fixed

Per BOCA compliance, the Exit Check is manually reset by authorized personnel after an alarm by closing the door and actuating the integral reset key switch or by momentarily closing a contact connected to the remote reset terminals. In addition, reset will be automatically initiated once the door has been opened, then closed and remains closed for 30 consecutive seconds.

(BOCA/Chicago)

The 101-DE/101-KDE operation complies with BOCA National Building Code and the Chicago Building Code: UL Listed, Special Locking Arrangements and Auxiliary Locks.

Option Code	Delay Release Time	Nuisance Time	Reset after Alarm	Lock Status on Power-Up
BD	15 sec Fixed	0 sec or 1 sec Selectable	Auto/Manual	Locked or Unlocked Selectable
BH	30 sec Fixed	0 sec or 1 sec Selectable	Auto/Manual	Locked or Unlocked Selectable
BC	15 sec Fixed	0 sec Fixed	Auto/Manual	Locked or Unlocked Selectable

KEY CYLINDER INSTALLATION

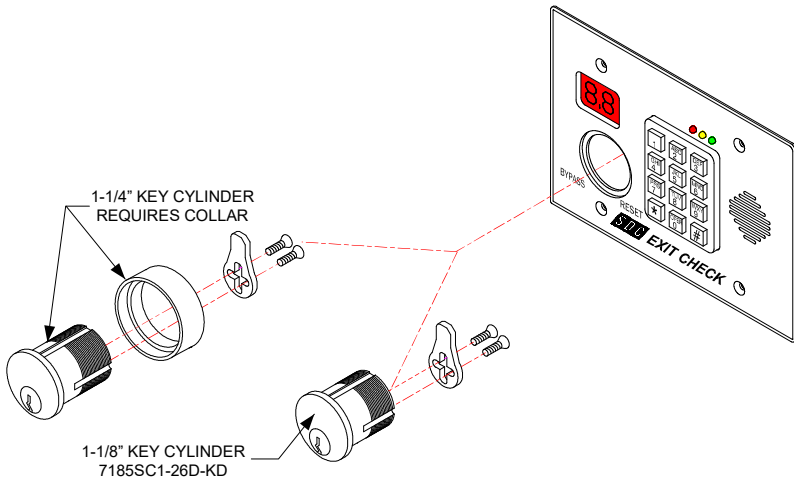

WITH KEY CYLINDER IN PROPER POSITION INSIDE SWITCH BLOCK, TIGHTEN THE SET SCREW TO LOCK CYLINDER IN PLACE.

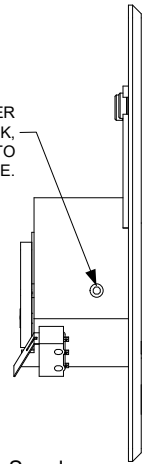

RECESSED MOUNTING DRY WALL

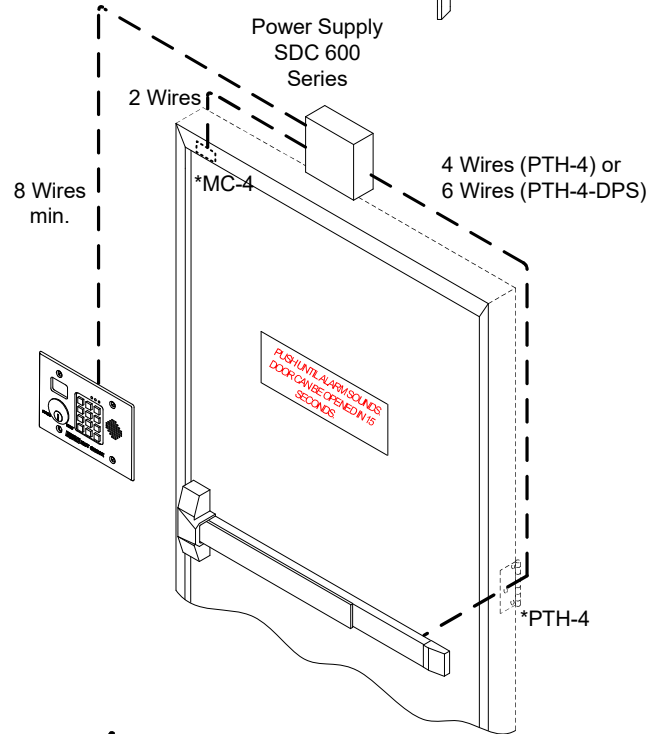
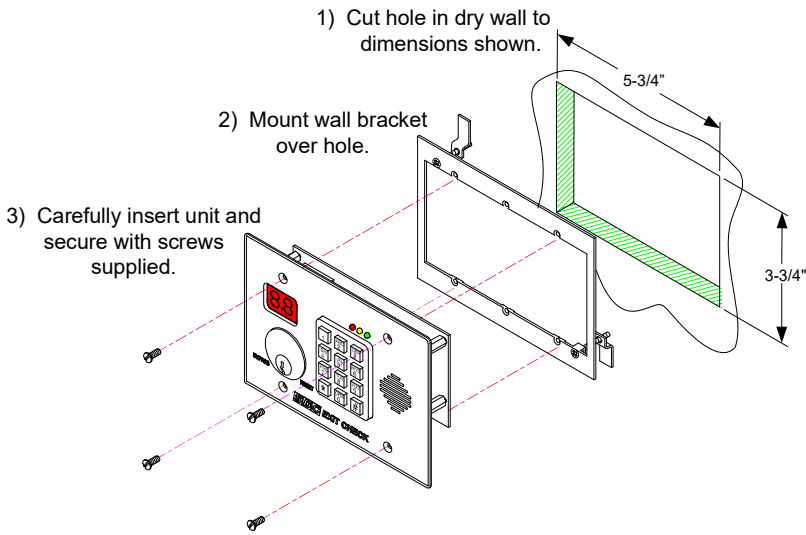

SURFACE MOUNT 3 GANG BOX OVER EXISTING RECESSED 2 GANG BOX

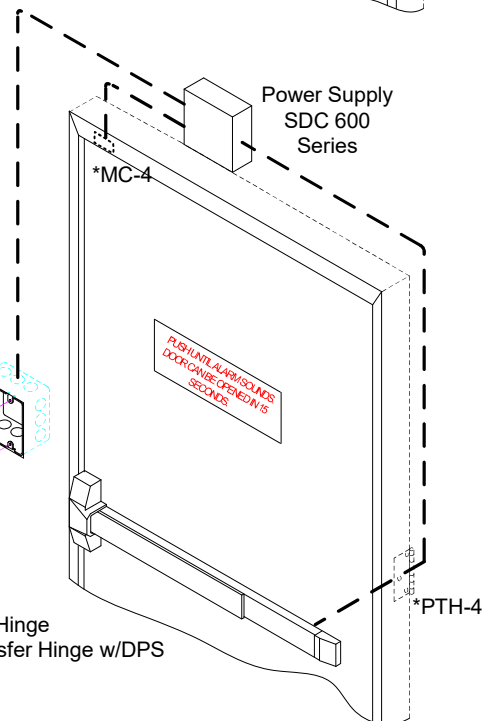
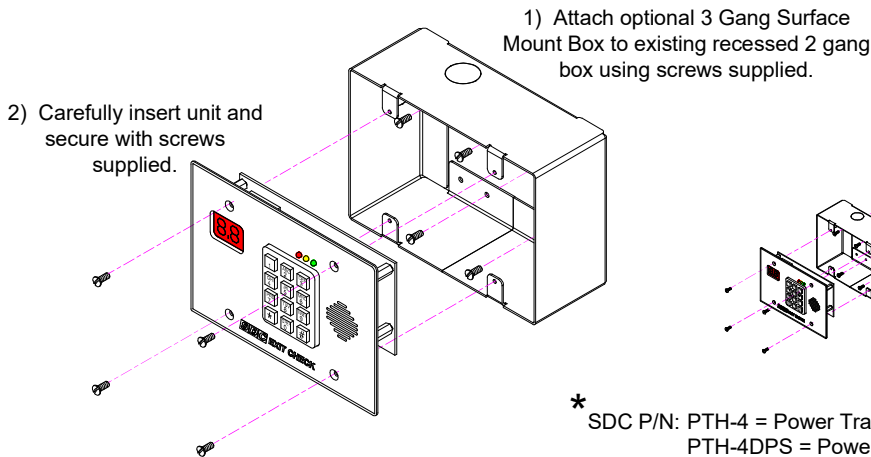

* SDC P/N: PTH-4 = Power Transfer Hinge
 PTH-4DPS = Power Transfer Hinge w/DPS
 MC-4 = Recessed DPS

RECOMMENDED MOUNTING PROCEDURE

USE 1-1/4" SCREWS SUPPLIED WITH WALL MOUNT FRAME TO HANG UNIT TEMPORARILY FOR WIRING PURPOSES

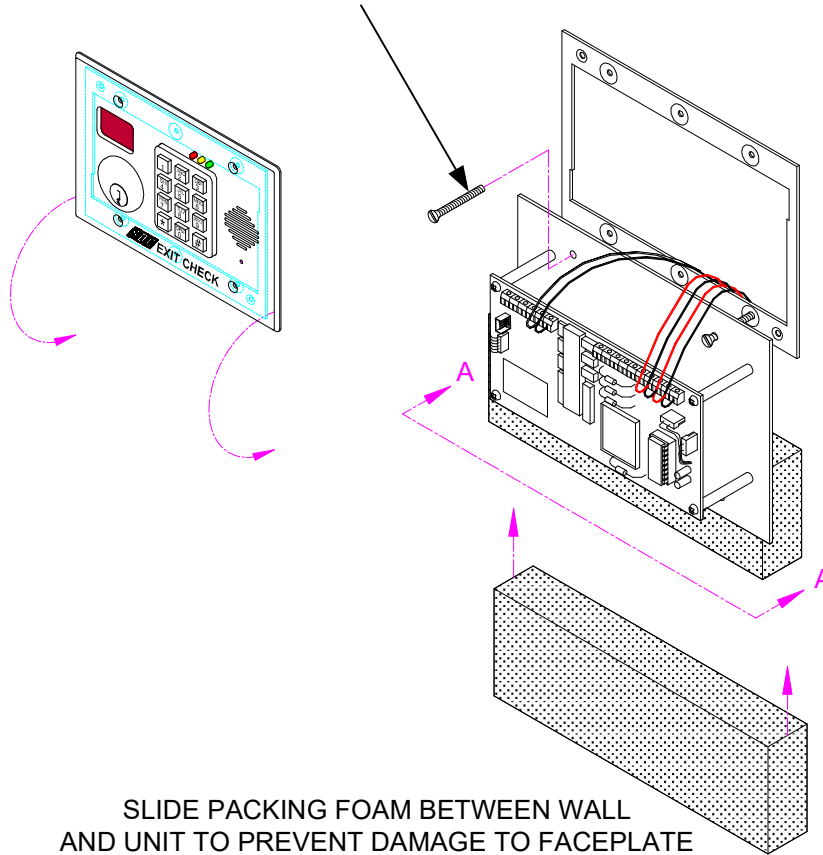

SLIDE PACKING FOAM BETWEEN WALL AND UNIT TO PREVENT DAMAGE TO FACEPLATE

VIEW A-A

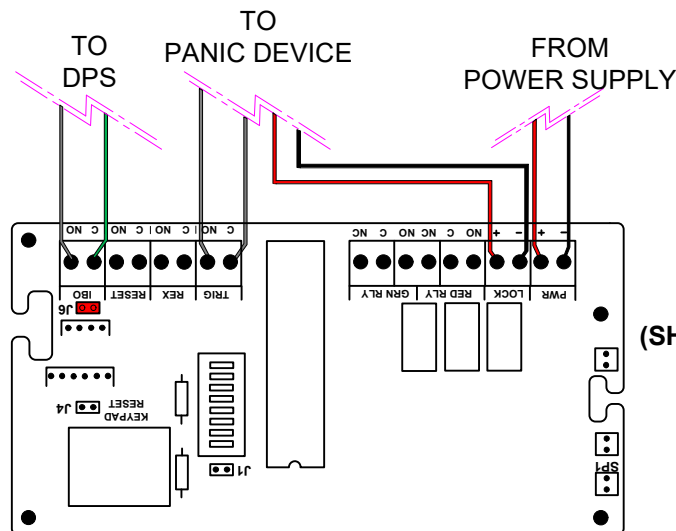

WIRE UNIT AS SHOWN (SHOWN WITH NO OPTIONS).

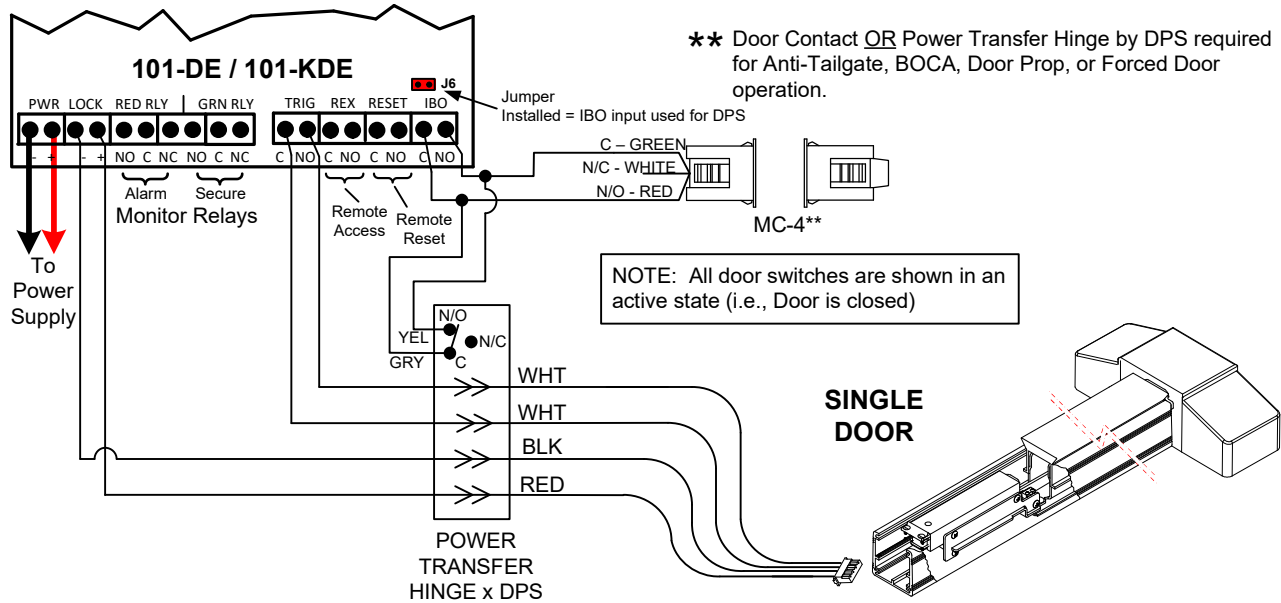

** Door Contact OR Power Transfer Hinge by DPS required for Anti-Tailgate, BOCA, Door Prop, or Forced Door operation.

NOTE: All door switches are shown in an active state (i.e., Door is closed)

Note: SDC 600 Series Power Supply required

Power Requirements	24VDC @ 430mA (Single) @ 680mA (Tandem)
Monitor Relays Contact Rating	SPDT (Dry) 1 Amp @12/24VDC (Resistive)
Operating Temp Range	0°C to 70°C

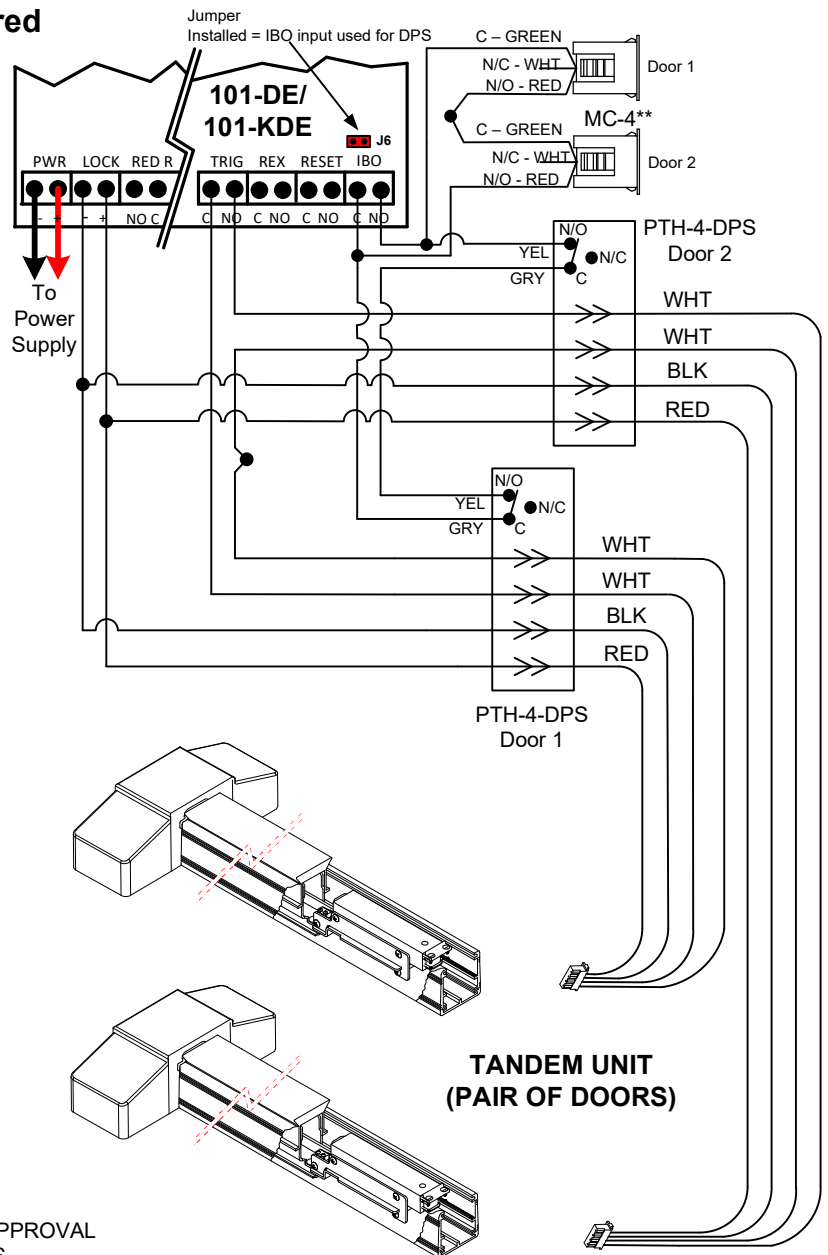

JUMPER J1 (DOOR PROP)

J1 INSTALLED: The S6000DE/KDE will enter the alarm mode if the door is held open past the request to exit period.

J1 REMOVED: The S6000DE/KDE will remain unlocked if the door is held open past the request to exit period. No alarm will sound.

JUMPER J1**

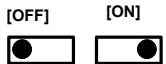
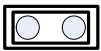

DIP SWITCH SETTINGS

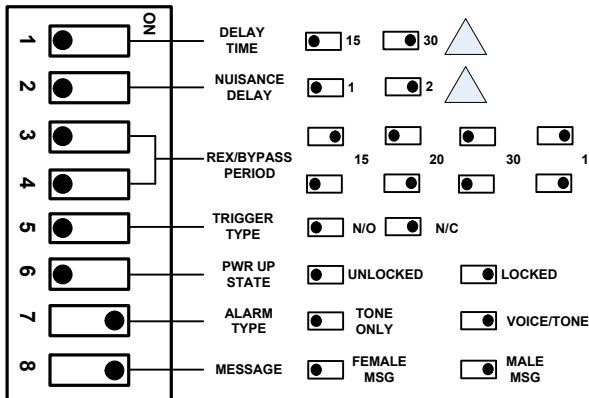

WARNING!
CONTACT THE AUTHORITY HAVING JURISDICTION FOR APPROVAL PRIOR TO SELECTING DELAY TIME OR PWR-UP SETTINGS



System Operation

POWER-UP UNLOCKED



The door is unlocked. To enter the Armed Mode, turn the keyswitch to Reset or enter the Reset Code "11★" on the keypad

POWER-UP LOCKED

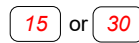

The door is locked and secure

DELAYED EGRESS MODE

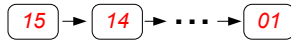

The door is still locked and secure. The display is counting down with audible alarm/voice instructions. Once the display reaches "00", the door will unlock.

ALARMED UNLOCKED [Alternating Display]



The door is unlocked and the alarm is sounding. To return to Armed Mode, close the door and turn the keyswitch to Reset or enter the Reset Code "11★" on the keypad



The door is unlocked and has been opened

RESET [Armed] → Keypad Code 11★

(Green LED solid)

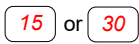

The door is locked and secure

AUTHORIZED EGRESS [REX] → Keypad Code 22★

(Green LED Solid)



Door Closed
Door has been opened

The door is unlocked until the REX timer has expired or until the door has been opened and then closed.

BYPASS [Maintained Unlock] → Keypad Code 33★

(Green LED Flashing)



Door Closed
Door has been opened

The door is unlocked indefinitely. To return to Armed Mode, enter the Reset Code "11★" on the keypad.

KDE Model Only:

KEY SWITCH BYPASS [Maintained Unlock]

(Green LED Solid)



Door Closed
Door has been opened

The door is unlocked indefinitely. To return to Armed Mode, close the door and turn the keyswitch to RESET or enter the Reset Code "11★" on the keypad.

Keypad Programming

KEYPAD STATUS LEDS

FACTORY PROGRAMMED CODES

GREEN Steady : Power on, No errors,
No outputs are active

Fast : No errors,
Flash At least one output is active

RED Steady : General error, invalid code entered

YELLOW Flash : For ADA requirements, it will light each time a key is pressed

Slow : Keypad is in Programming Mode
Flash

User No.	Pin Code	Output Code	Function
01	1234★	NA	Master Code (default)
02	11★	2	Reset
03	22★	3	Authorized Exit (Rex)
04	33★	4	Bypass

If the factory programmed codes are acceptable for your installation, no additional programming is required.



Changing the Master Code

User 1 is always used as the Master Code and is required to access keypad programming. The Factory Default Master Code is "1234". It is strongly recommended that a new Master Code is assigned after installation. **WRITE DOWN THE NEW CODE.** If the master code is lost, you must use the keypad reset jumper on the main circuit board to enter programming mode by using the Default Master Code.

To Change the Master Code (User 1)

- 1) Enter Programming Mode: Press 99# Master Code* .
- 2) Assign new Master Code : Press 1# 01# New Pin Code# Output Relay #* .

For example: 99# 1234*1# 01# 3871# 0#* changes the Master code from 1234 to 3871.

- 3) Press ** to exit programming mode.

Entering Programming Mode

Press 99# Master Code* .

For example: 99# 1234* Enters programming mode using the Default Master Code.

Adding a User / Changing User Pin Codes (Option 1)

To add a user:

Press 1# User Number (2 digits)# New Pin Code# Output Relay #* .

For example: 1# 05# 55# 2#* adds user 5's pin code as one that will activate authorized exit.

Output Relay Codes

- 2= Reset
- 3= Authorized Exit
- 4= Bypass

Deleting a User (Option 2)

To delete a user:

Press 2# User Number (2 digits)#* .

For example: 2# 05#* deletes user 5.

Erase All Users (Option 8)

To **ERASE ALL USERS!!**

Press 8#* .

All users are erased and the Default Master Code is reset to 1234.

Exit Programming Mode

Press ** .

Returning the Keypad to Factory Default Settings

Short the **Keypad Reset [J4]** jumper terminal located on the main controller board.

Press 99# 1234*8#* .

Press 3#1#2#* . Sets the Output #1 (Reset) for 2 seconds.

Press 3#2#2#* . Sets the Output #2 (Auth Exit) for 2 seconds.

Press 3#3#0#* . Sets the Output #3 (Bypass) for latching.

Press 1#02#11#2#* . Adds user # 2 with a code of 11. [Reset]

Press 1#03#22#3#* . Adds user # 3 with a code of 22. [Auth Exit]

Press 1#04#33#4#* . Adds user # 4 with a code of 33. [Bypass]

Press ** to exit programming mode.

Remove the shorting jumper from the **Keypad Reset** terminal.

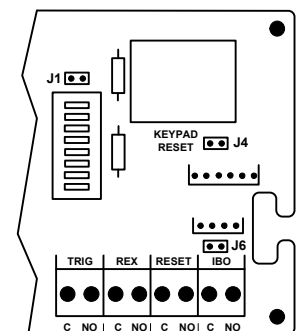

Connecting to a Infant/Patient Monitoring System

1. Locate jumper [J6] (above the IBO input). Verify that it is NOT installed across both pins.
2. Close AND hold the REX input. The 101-DE will be in Bypass Mode and will be unlocked.
3. Whenever the IBO input is closed AND held, the 101-DE will immediately relock and rearm. Egress is possible by activating the Exit Check's trigger input and initiating the irreversible 15 or 30 second unlock cycle.
4. Releasing the IBO input will return the 101-DE to the Bypass Mode.
5. Releasing the REX input will rearm the system.
6. Upon power-up, you must manually reset the lock to activate the IBO input.

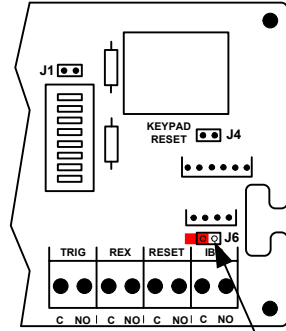

Jumper Removed = IBO input used for Patient Monitoring

Connection to a Infant/Patient Monitoring System has not been investigated by UL.

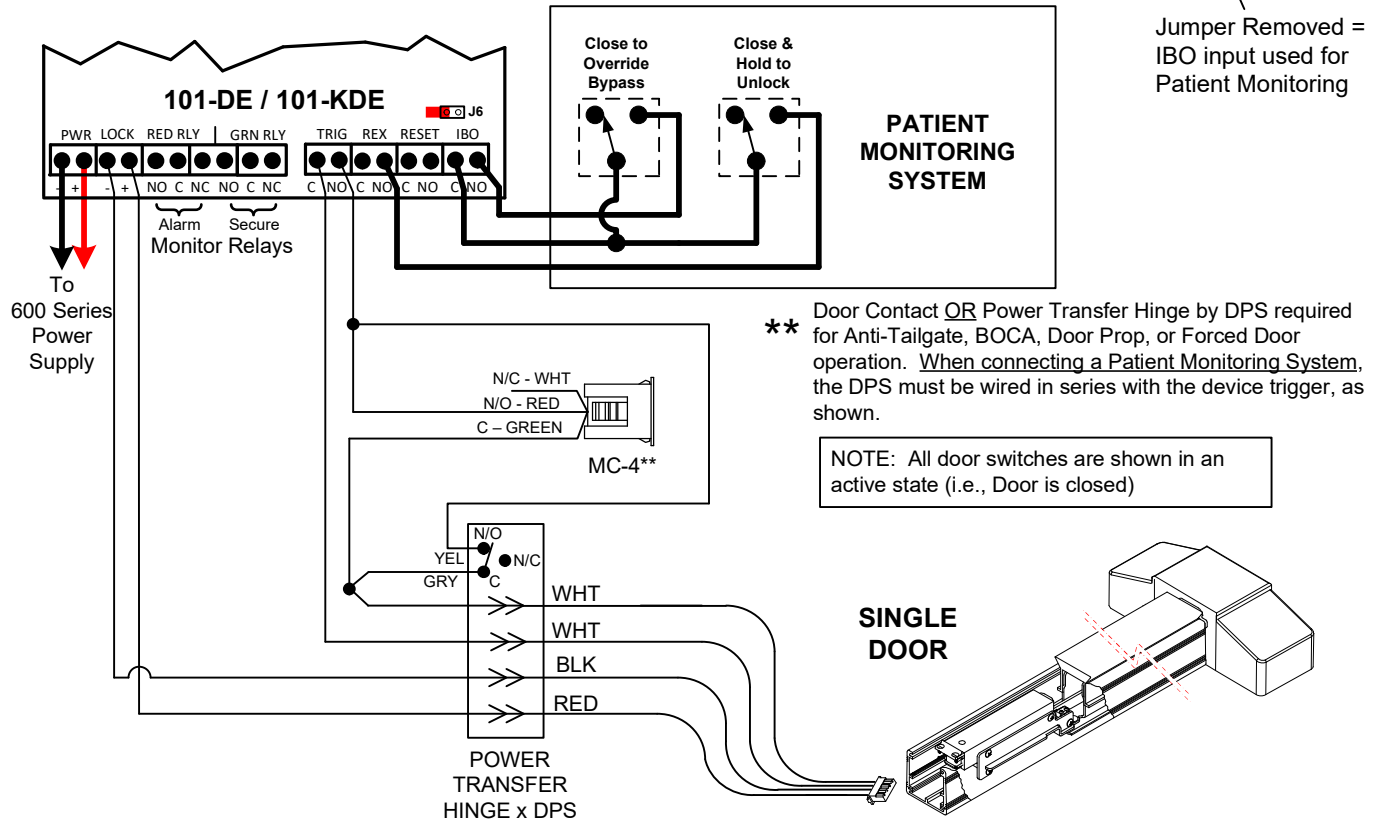

Connecting Optional Accessories

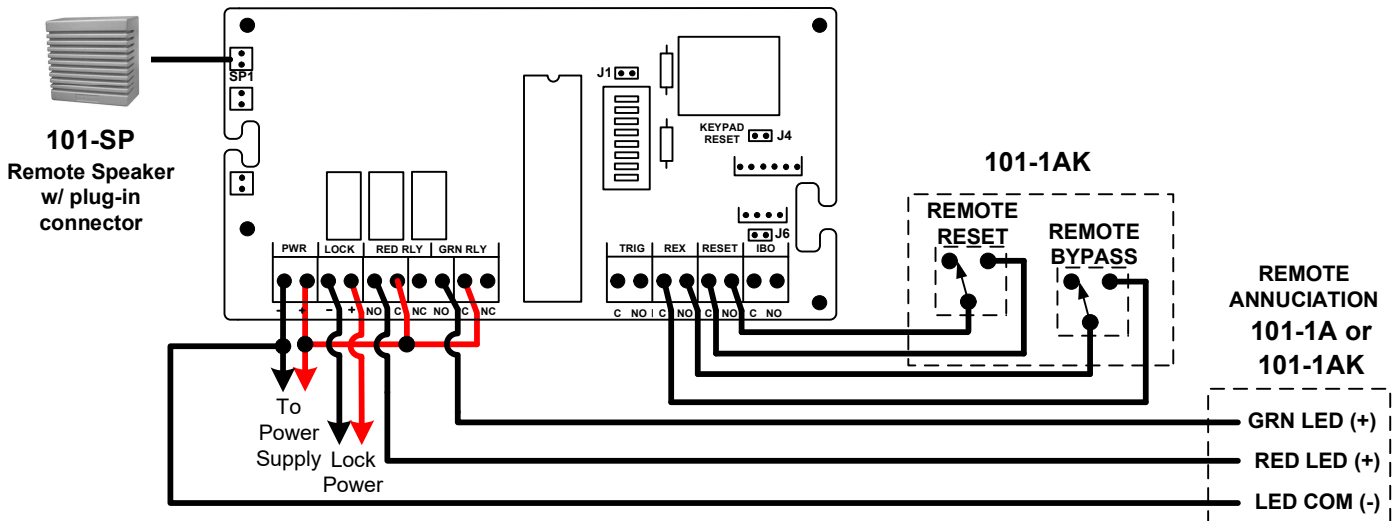



INSTALLATION INSTRUCTIONS

S6100 SERIES RIM PANIC/FIRE EXIT DEVICES

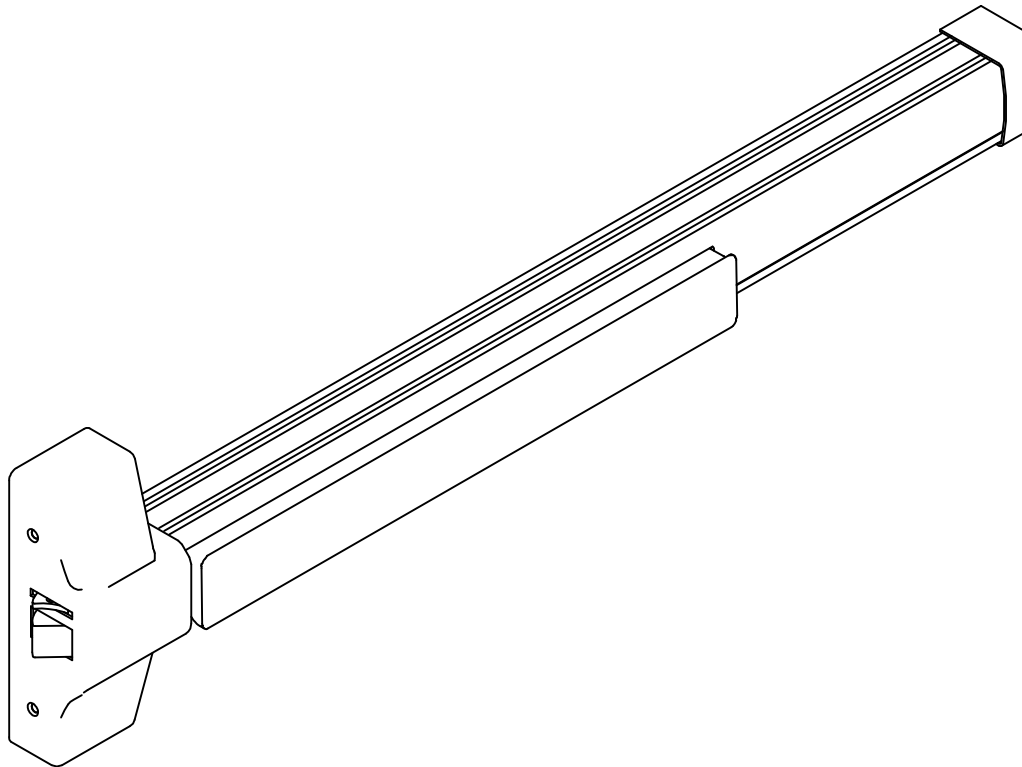

These instructions are presented a in step by step sequence. Please read it through **before** installation.

Note:

The dimensions of the Template are shown in inches. See attached page for the Metric Conversion Table for millimeters.

A. DESIGNATION OF PARTS

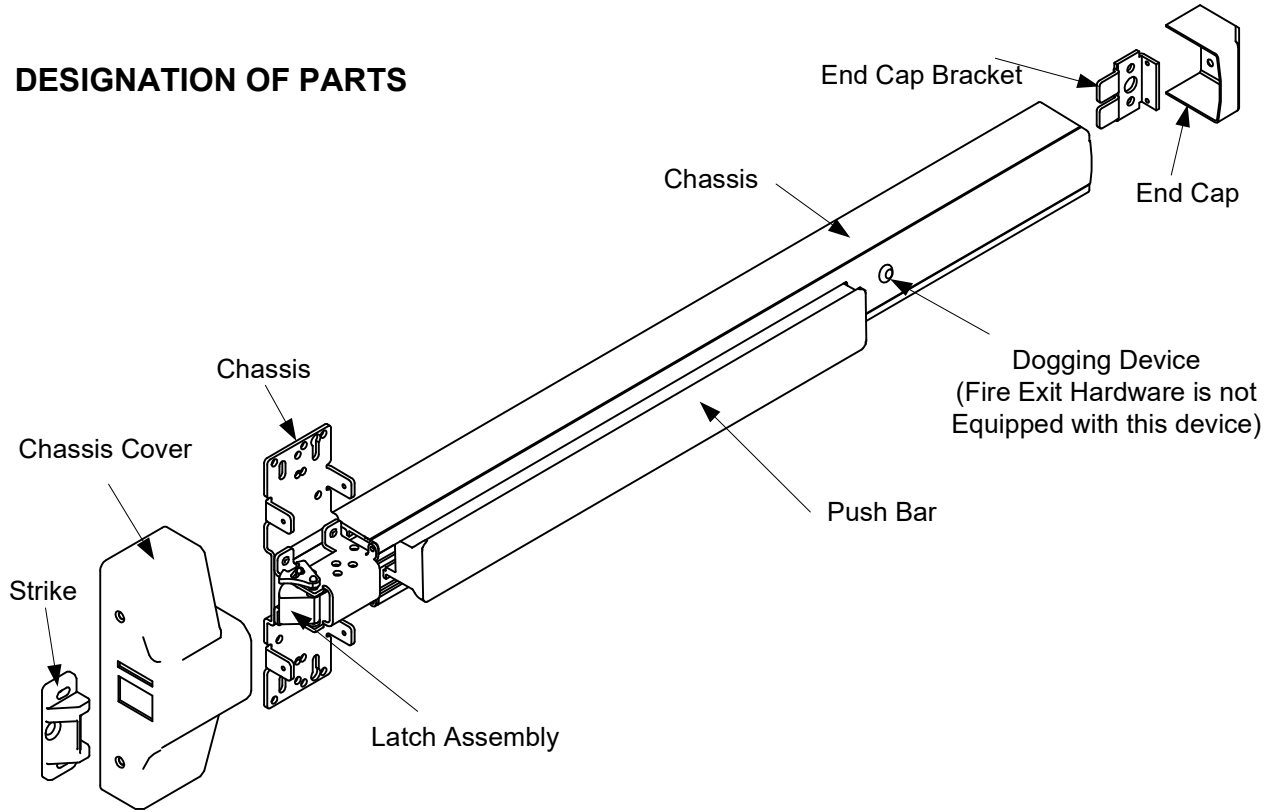

B. TYPE OF INSTALLATION

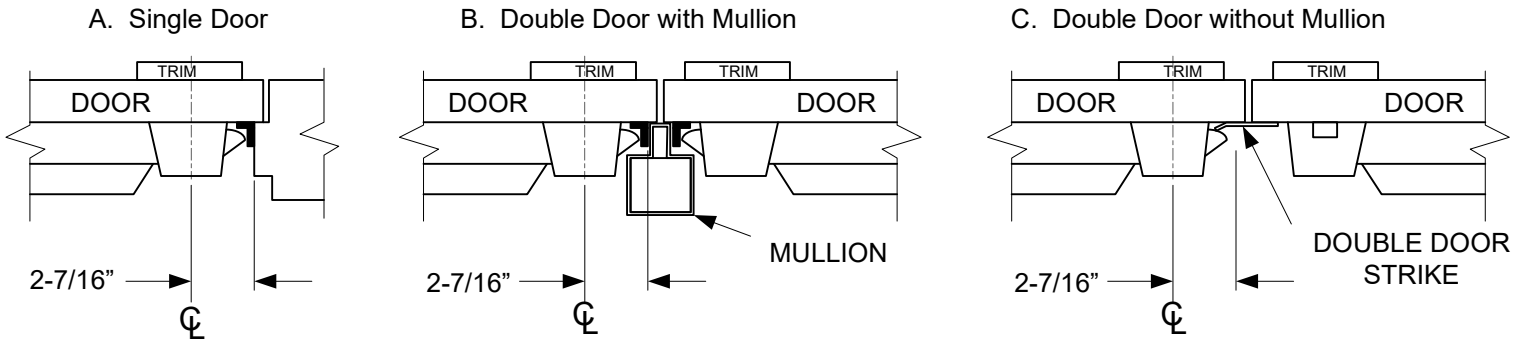

C. MARK POSITION FOR INSTALLING

1. Mark the center line of device by drawing a line across the door and stop 40" above the finished floor as shown at right.
2. Prepare door for you specific device per supplied template.
3. Drill holes as marked on door and jamb or mullion.

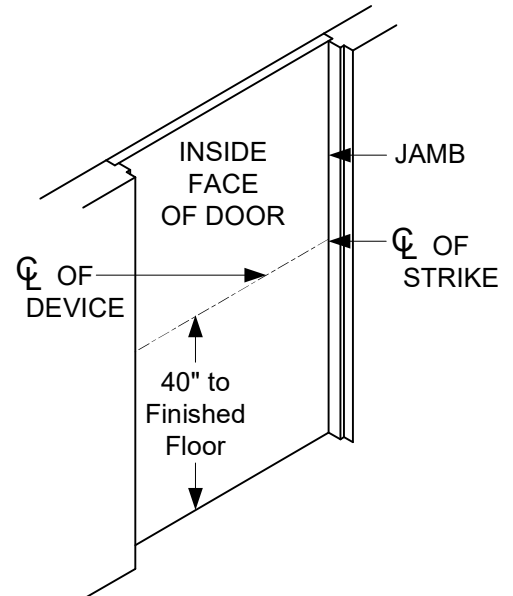

D. INSTALL STRIKE TO FRAME

1. Place strike over the drilled holes, and attach it to the jamb or mullion with the supplied screws.
2. If installing with a vertical rod device for double doors, and additional Double Door Strike must be used in place of the regular strike provided.

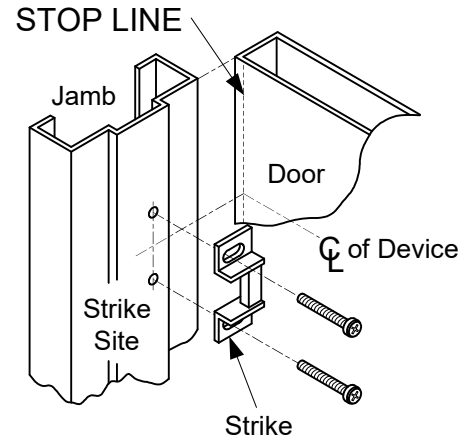

E. IF CYLINDER IS INCLUDED WITH THE DEVICE

1. Drill one 1-3/16" diameter thru hole for the cylinder/bracket plate.
2. Insert cylinder and cylinder collar from outside of door.
3. Place bracket plate on inside of face of the door.
4. Put two cylinder mounting screws through the bracket plate and into the cylinder.
5. Cut the cylinder mounting screws and tailpiece to the required door thickness at break-off points, then fasten screws.

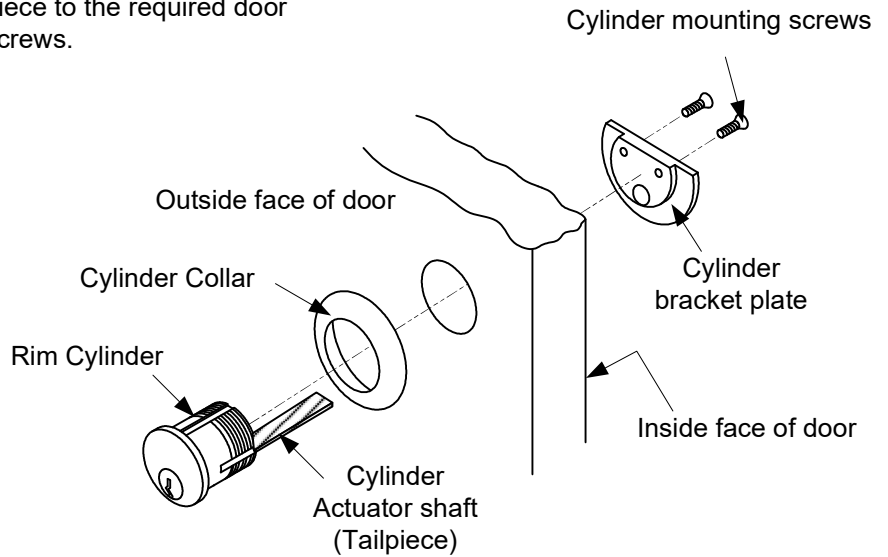
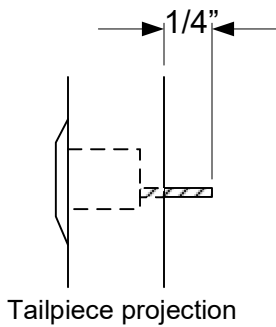

F. INSTALL OUTSIDE TRIM

Mark and drill holes for the outside trim (see trim instructions).

E. INSTALL DEVICE BODY

1. Remove chassis cover from latch assembly and end cap from end cap bracket.
2. Place the device horizontally over the drilled holes and attach with the supplied mounting screws. Bolt device chassis to trim with sexbolts (if required).
3. Make sure cylinder or trim actuator shaft (tailpiece) can insert into device cam concentrically (see device cam at right).
4. Install end cap bracket on device, then screw to door.
5. Tighten all screws or bolts.

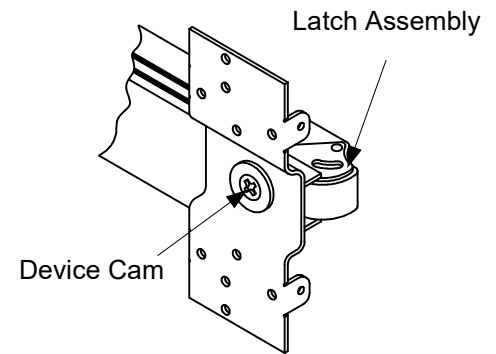

Insert Trim Actuator Shaft Into device cam "+".

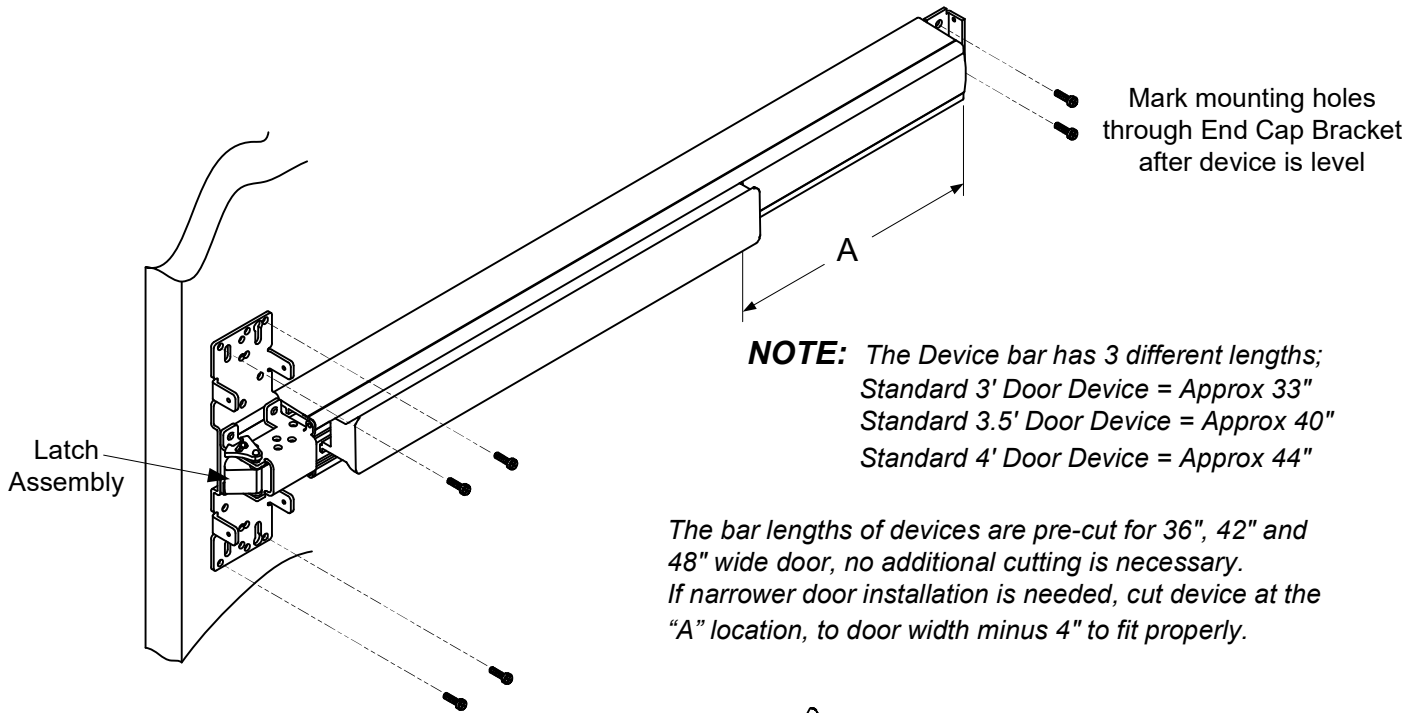

NOTE: The Device bar has 3 different lengths;
 Standard 3' Door Device = Approx 33"
 Standard 3.5' Door Device = Approx 40"
 Standard 4' Door Device = Approx 44"

The bar lengths of devices are pre-cut for 36", 42" and 48" wide door, no additional cutting is necessary. If narrower door installation is needed, cut device at the "A" location, to door width minus 4" to fit properly.

H. INSTALL COVERS

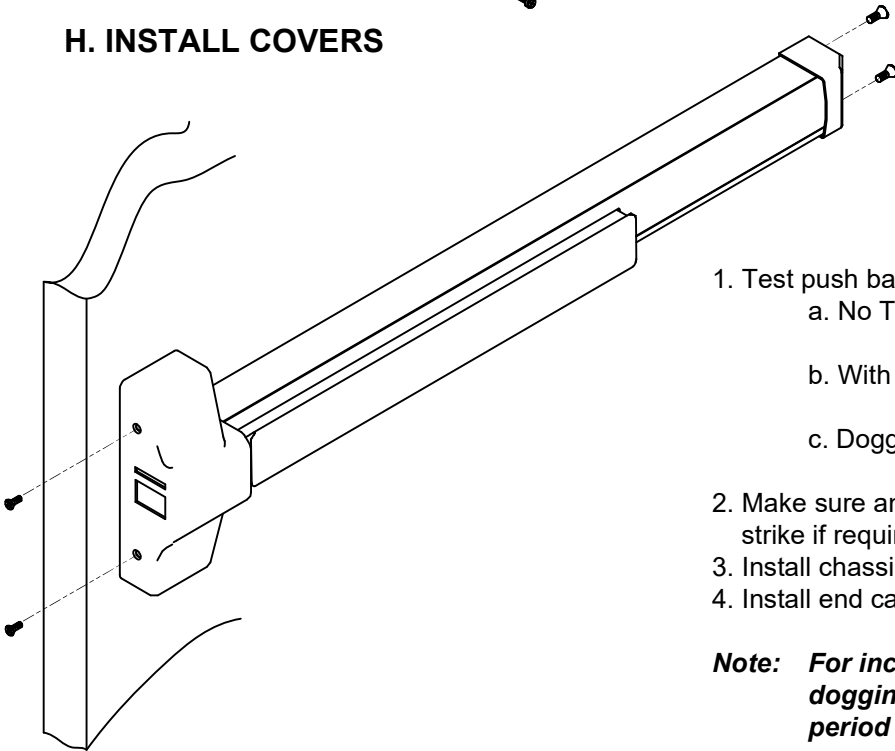

1. Test push bar operation before installing covers:
 - a. No Trim: Latch bolt is retracted by push bar inside.
 - b. With Trim: Latch bolt is retracted by push bar inside, key or lever/knob outside.
 - c. Dogging: See dogging description and chart below.
2. Make sure and secure latch bolt engagement. Adjust strike if required.
3. Install chassis cover on chassis.
4. Install end cap.

Note: For increasing the life of this device, dogging device during high traffic period of the day (Panic device only).

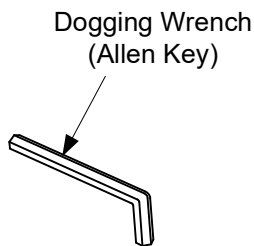

Dogging:
 Depress push bar,
 Insert dogging wrench
 and turn clockwise 35 degrees.

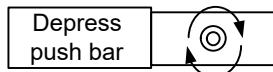

The push bar will remain depressed and the latch will remain retracted

Release Dogging:
 Depress push bar,
 Insert dogging wrench and
 turn counter-clockwise 35 degrees.

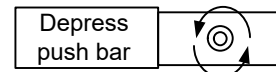

The push bar will return to up position and the latch will project to lock the door.