

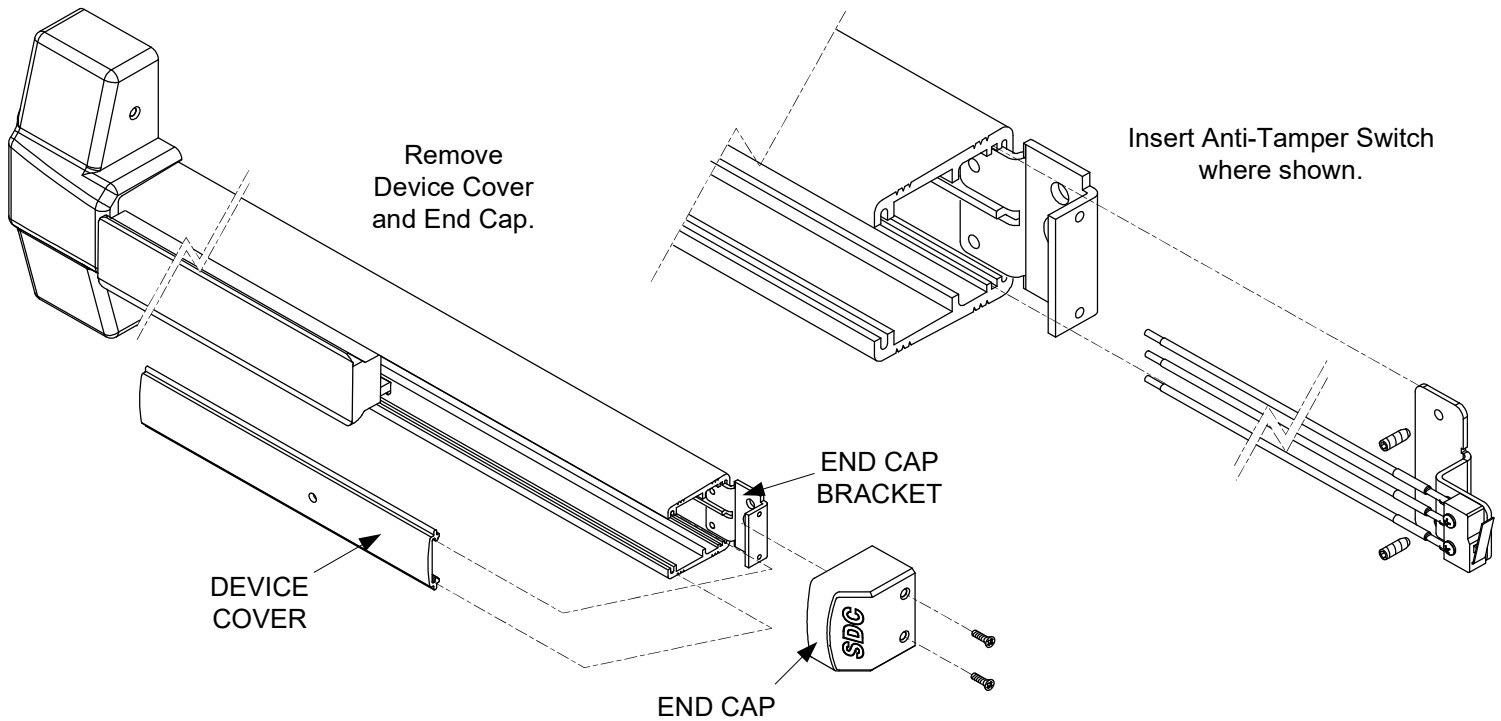

INSTALLATION INSTRUCTIONS

S6000-ATS ANTI-TAMPER SWITCH KIT



Insert the S6000-ATS assembly into the device as illustrated above. Slide the End Cap over the End Cap Bracket. Position the S6000-ATS assembly so that the switch arm makes contact with the inside surface of the End Cap. While the assembly is in position fasten the provided set screws on the S6000-ATS to lock it in place.

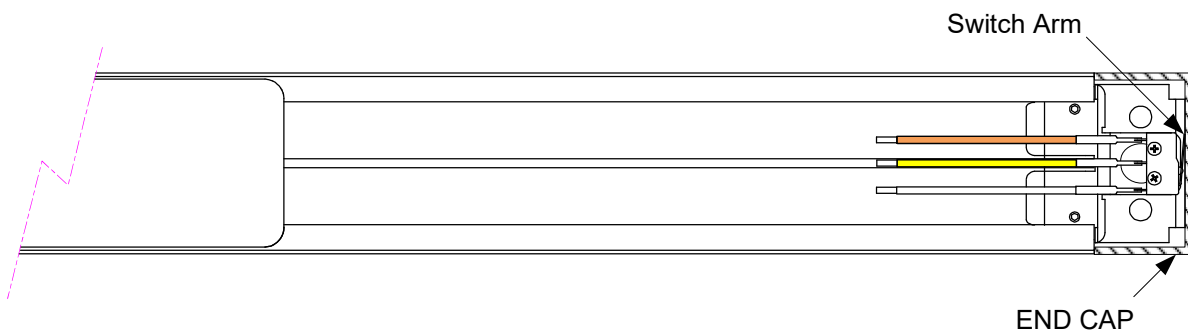

Once the S6000-ATS monitoring switch assembly is properly secure within the device, wire the switch and re-install the Device Cover and End Cap.

Electrical Specifications:

WHT = COM
 YEL = N/O
 ORG = N/C
 5AMPS @ 250V
 Resistive

Any suggestions or comments to this instruction or product are welcome. Please contact us through our website or email engineer@sdsecurity.com